

12888B2-A CUCKOO MODULE

CUCKOO MECHANISM

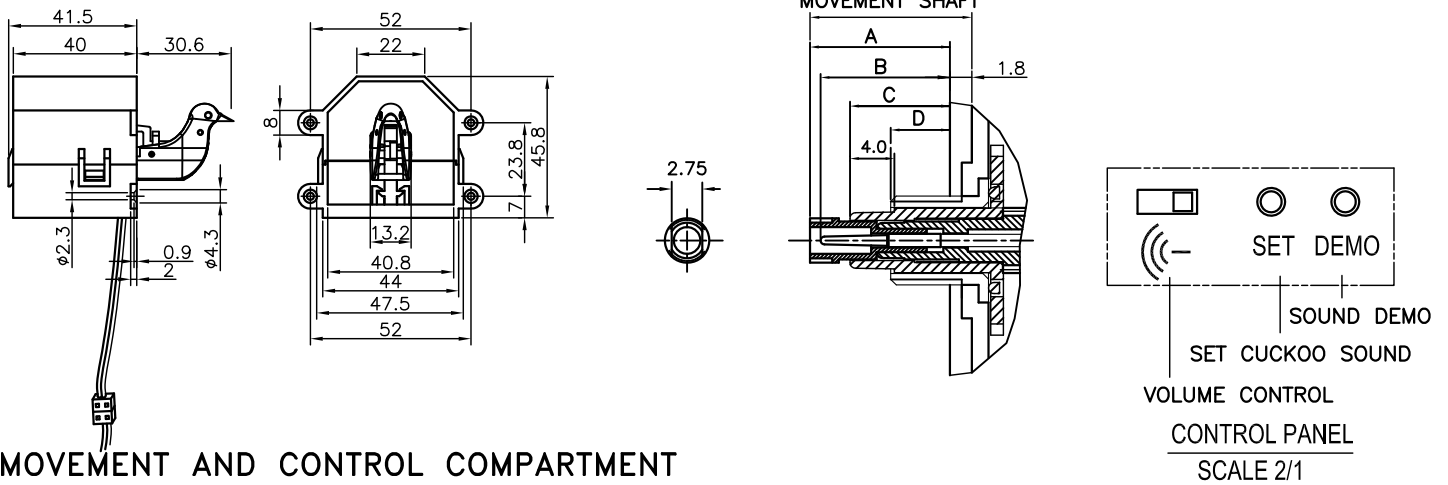

MOVEMENT AND CONTROL COMPARTMENT

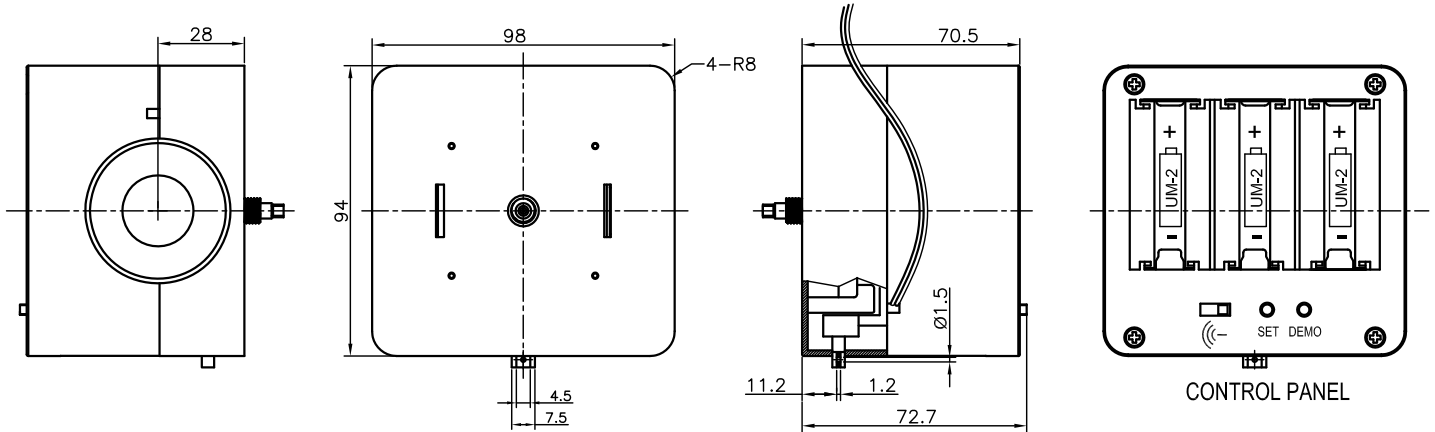

CUCKOO/PENDULUM TRIGGER MOVEMENT (CUCKOO MODULE +PENDULUM TRIGGER MOVEMENT)

*UNIT:m/m

ITEM NO.	MOVEMENT TYPE	A	B	C	D	Description
B2-ADM3MC	12888B2-A + 12888DM3MCEL	21.7	20.9	18.2	14.2	Max. Pendulum Swing : 14'
B2-ADM3MC1	12888B2-A + 12888DM3MC1EL	15.2	14.4	11.7	7.7	Max. Pendulum Weight : 40g
B2-ADM3MC5	12888B2-A + 12888DM3MC5EL	18.2	17.3	14.7	10.2	Max. Pendulum Length : 30cm

SPECIFICATIONS :

- Operating Voltage : 12888DM3MCEL Pendulum Trigger Movement 1.3V ~ 1.7V
 12888B2-A Cuckoo Module 2.5V ~ 3.2V
- Current Consumption : Trigger Pendulum Movement Less Than 250~270 μ A At 1.5V DC.
 Cuckoo Module Less Than 150 mA At 3V DC.
- Torque at Second Hand : \leq 0.6(gf-cm)
 Torque at Minute Hand : \leq 36(gf-cm)
- Operating Temperature Range : -10°C ~ +60°C
- Battery Life : Trigger Pendulum Movement - use 1pc UM-2 size C about 12 months (battery not included)
 Cuckoo Module - use 2pcs UM-2 size C about 12 months (battery not included)

FUNCTIONS:

- Bird chirps and sounds cuckoo, flaps wings on the hour
 Volume switch